

### Perspirometer

#### **HILAB model H040**

**Purpose** – Determination of the colour fastness to water and to perspiration, according **ISO 11641**; **ISO 11642**; **ISO 105-E01**; **ISO 105-E04**.

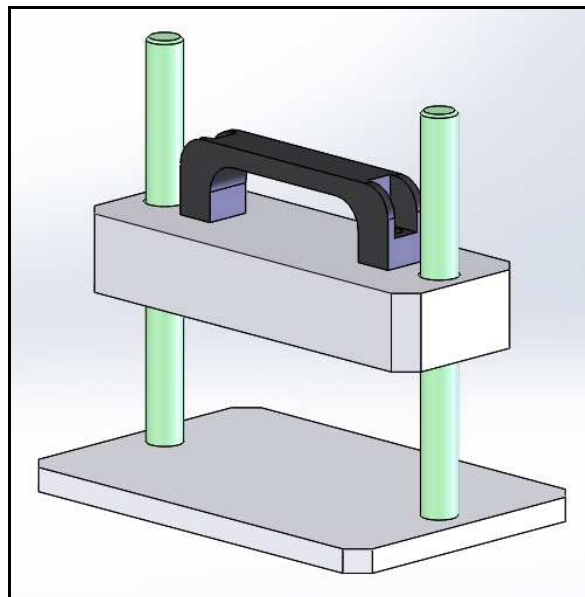

This perspirometer is supplied complete with 20 acrylic plates with 1,5 mm thickness.

**NOTE** – All parts are made with stainless steel to avoid oxidation and sample contamination.

<b>Dimensions (W x H x D)</b>	(mm)	150 x 100 x 220
<b>Net Weight (including base)</b>	(Kg)	6,2

Due continuous technical development, we reserve the right to introduce changes in the product, without previous notice.

**HILAB – Test Equipments & Consulting**

Rua 16 de Maio, 308

3700-100 S. João da Madeira – Portugal

Tel. 00 351 916927147; 910777803 – emails: [yg@hilab.pt](mailto:yg@hilab.pt)-- [p.silva@hilab.pt](mailto:p.silva@hilab.pt)